

# DS2003 High Current/Voltage Darlington Drivers

## General Description

The DS2003 is comprised of seven high voltage, high current NPN Darlington transistor pairs. All units feature common emitter, open collector outputs. To maximize their effectiveness, these units contain suppression diodes for inductive loads and appropriate emitter base resistors for leakage.

The DS2003 has a series base resistor to each Darlington pair, thus allowing operation directly with TTL or CMOS operating at supply voltages of 5.0V.

The DS2003 offers solutions to a great many interface needs, including solenoids, relays, lamps, small motors, and

LEDs. Applications requiring sink currents beyond the capability of a single output may be accommodated by paralleling the outputs.

## Features

- Seven high gain Darlington pairs
- High output voltage ( $V_{CE} = 50V$ )
- High output current ( $I_C = 350\text{ mA}$ )
- TTL, PMOS, CMOS compatible
- Suppression diodes for inductive loads
- Extended temperature range

## Connection Diagram

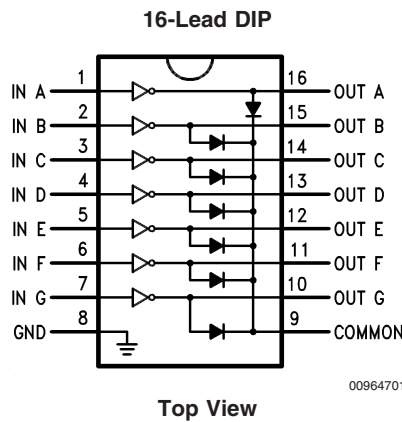

## Order Numbers

Operating Temperature Range	N Package Number N16E	SOIC Package Number M16A	TSSOP Package Number MT16
-40°C to +125°C	DS2003TN	DS2003TM	DS2003TMT
-40°C to +85°C	DS2003CN	DS2003CM	-

**Absolute Maximum Ratings** (Note 1)

If Military/Aerospace specified devices are required, please contact the National Semiconductor Sales Office/Distributors for availability and specifications.

Storage Temperature Range	-65°C to +150°C
Operating Temperature Range, $T_A$	
DS2003T	-40°C to +125°C
DS2003C	-40°C to +85°C
Junction Temperature Range, $T_J$	-40°C to +150°C
Lead Temperature	
Soldering, 10 seconds	265°C

## ESD Ratings

Human Body Model	+/-2000V
Machine Model	+/- 200V

## Package Thermal Dissipation Ratings

MT16 Package $\theta_{J-A}$	130°C/W
N16E Package $\theta_{J-A}$	88°C/W
M16A Package $\theta_{J-A}$	115°C/W

Input Voltage	-0.3V to 30V
Output Voltage	55V
Emitter-Base Voltage	6.0V
Continuous Collector Current	500 mA
Continuous Base Current	25 mA

**Electrical Characteristics**

$T_A = 25^\circ\text{C}$ , unless otherwise specified (Note 2)

Symbol	Parameter	Conditions	Min	Typ	Max	Units
$I_{CEX}$	Output Leakage Current	$T_A = 25^\circ\text{C}$ , $V_{CE} = 50\text{V}$ (Figure 1)			20	$\mu\text{A}$
		$T_A = 85^\circ\text{C}$ , $V_{CE} = 50\text{V}$ (Figure 1)			100	
		$T_A = 125^\circ\text{C}$ , $V_{CE} = 50\text{V}$ (Figure 1) for DS2003T			150	
$V_{CE(Sat)}$	Collector-Emitter Saturation Voltage	$I_C = 350\text{mA}$ , $I_B = 500\mu\text{A}$ (Figure 3) (Note 3)		1.25	1.6	V
		$I_C = 200\text{mA}$ , $I_B = 350\mu\text{A}$ (Figure 3)		1.1	1.3	
		$I_C = 100\text{mA}$ , $I_B = 250\mu\text{A}$ (Figure 3)		0.9	1.1	
$I_{I(ON)}$	Input Current	$V_I = 3.85\text{V}$ (Figure 4)		0.93	1.35	mA
$I_{I(OFF)}$	Input Current (Note 4)	$I_C = 500\mu\text{A}$ (Figure 5)	50	100		$\mu\text{A}$
		$T_A = +25^\circ\text{C}$	50	100		$\mu\text{A}$
		$T_A = +85^\circ\text{C}$	25	50		$\mu\text{A}$
		$T_A = +125^\circ\text{C}$ for DS2003T	10	25		$\mu\text{A}$
$V_{I(ON)}$	Input Voltage (Note 5)	$V_{CE} = 2.0\text{V}$ , $I_C = 200\text{mA}$ (Figure 6)			2.4	V
		$V_{CE} = 2.0\text{V}$ , $I_C = 250\text{mA}$ (Figure 6)			2.7	
		$V_{CE} = 2.0\text{V}$ , $I_C = 300\text{mA}$ (Figure 6)			3.0	
$C_I$	Input Capacitance			15	30	pF
$t_{PLH}$	Turn-On Delay	$0.5 V_I$ to $0.5 V_O$			1.0	$\mu\text{s}$
$t_{PHL}$	Turn-Off Delay	$0.5 V_I$ to $0.5 V_O$			1.0	$\mu\text{s}$
$I_R$	Clamp Diode Leakage Current	$V_R = 50\text{V}$ (Figure 7)				
		$T_A = 25^\circ\text{C}$		5	10	$\mu\text{A}$
		$T_A = 85^\circ\text{C}$		10	50	$\mu\text{A}$
		$T_A = 125^\circ\text{C}$ for DS2003T		20	100	$\mu\text{A}$
$V_F$	Clamp Diode Forward Voltage	$I_F = 350\text{mA}$ (Figure 8)		1.7	2.0	V

**Note 1:** "Absolute Maximum Ratings" are those values beyond which the safety of the device cannot be guaranteed. They are not meant to imply that the devices should be operated at these limits. The tables of "Electrical Characteristics" provide conditions for actual device operation.

**Note 2:** All limits apply to the complete Darlington series except as specified for a single device type.

**Note 3:** Under normal operating conditions these units will sustain 350 mA per output with  $V_{CE(Sat)} = 1.6\text{V}$  at  $70^\circ\text{C}$  with a pulse width of 20 ms and a duty cycle of 30%.

**Note 4:** The  $I_{I(OFF)}$  current limit guaranteed against partial turn-on of the output.

**Note 5:** The  $V_{I(ON)}$  voltage limit guarantees a minimum output sink current per the specified test conditions.

# Typical Performance Characteristics

**Collector Current vs Saturation Voltage**

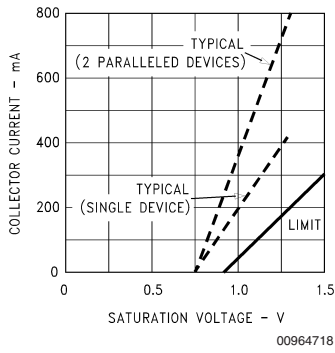

**Collector Current vs Input Current**

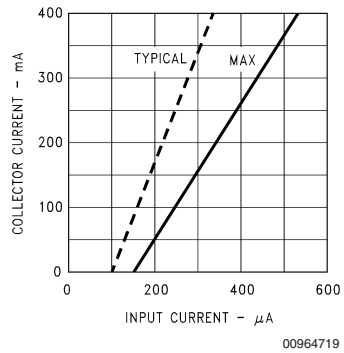

**Input Current vs Input Voltage**

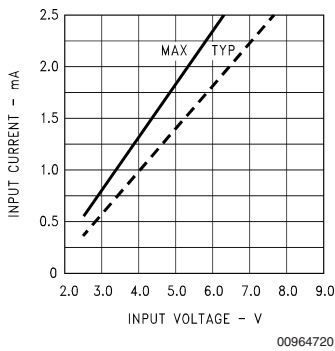

**Peak Collector Current vs Duty Cycle and Number of Outputs (N16E Package)**

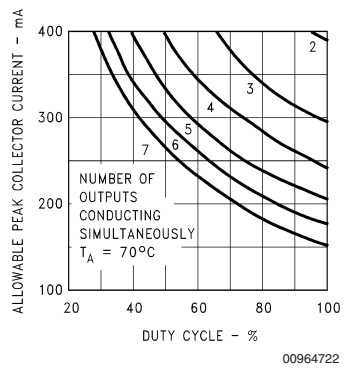

## Equivalent Circuits

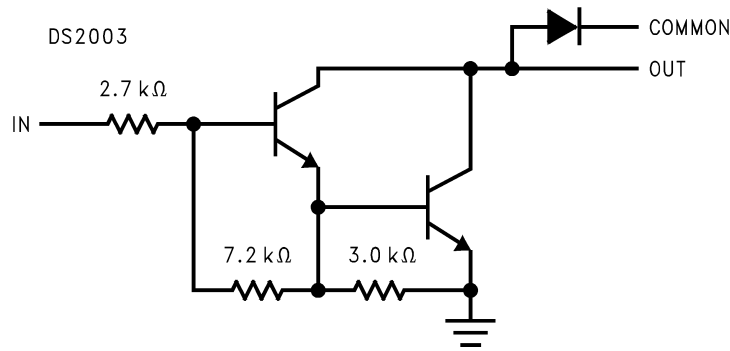

# Test Circuits

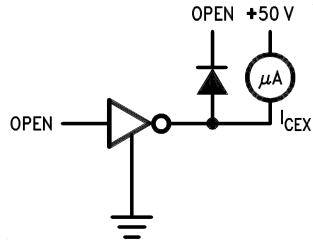

00964707

FIGURE 1.

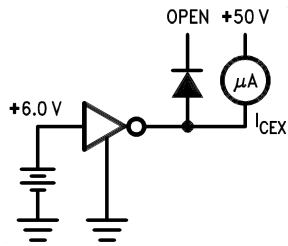

00964708

FIGURE 2.

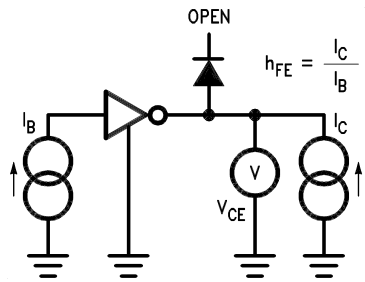

00964709

FIGURE 3.

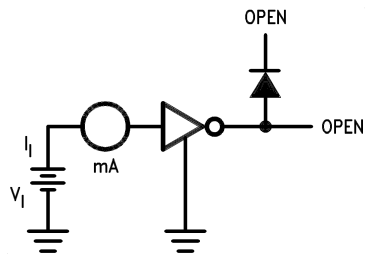

00964710

FIGURE 4.

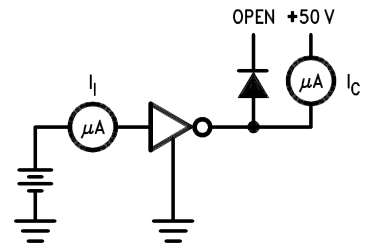

00964711

FIGURE 5.

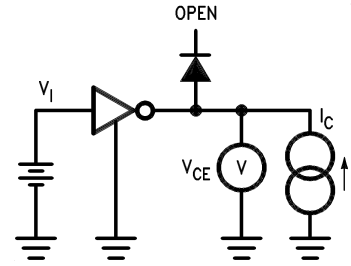

00964712

FIGURE 6.

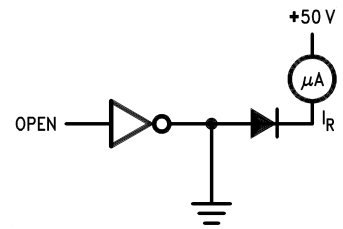

00964713

FIGURE 7.

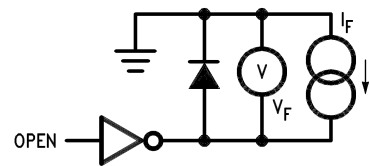

00964714

FIGURE 8.

**Physical Dimensions** inches (millimeters) unless otherwise noted

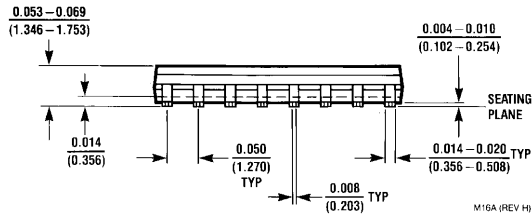
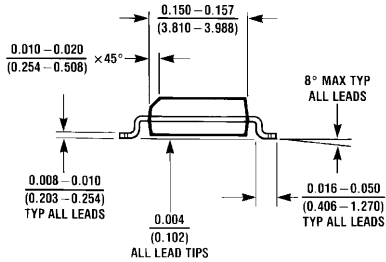
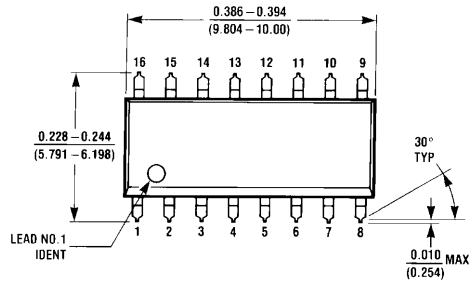

**SOIC Package (M)**  
**Order Number DS2003CM, DS2003TM**  
**NS Package Number M16A**

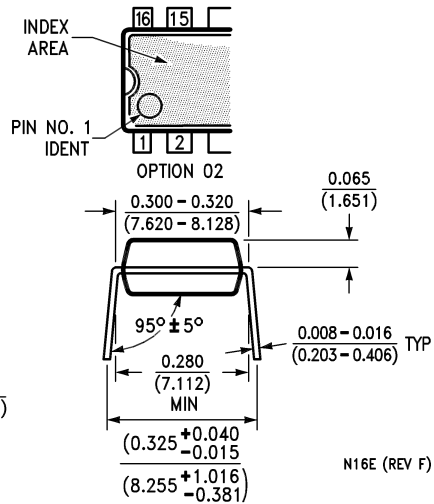
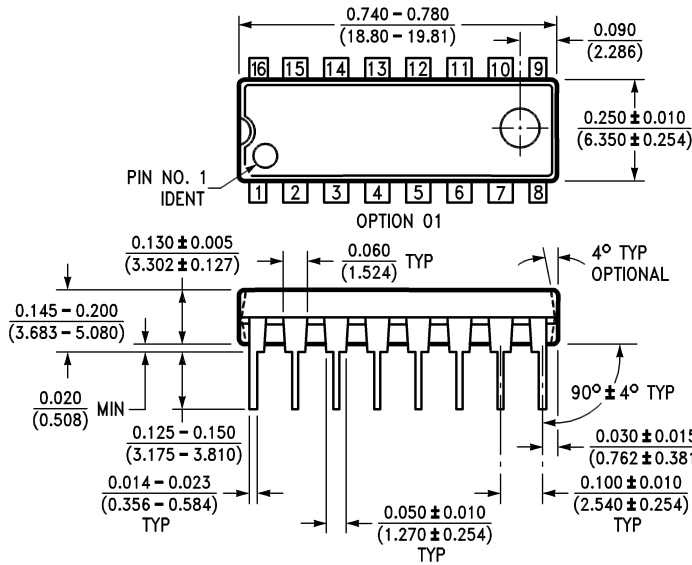

**Molded Dual-In-Line Package (N)**  
**Order Number DS2003CN, DS2003TN**  
**NS Package Number N16E**

**Physical Dimensions** inches (millimeters) unless otherwise noted (Continued)

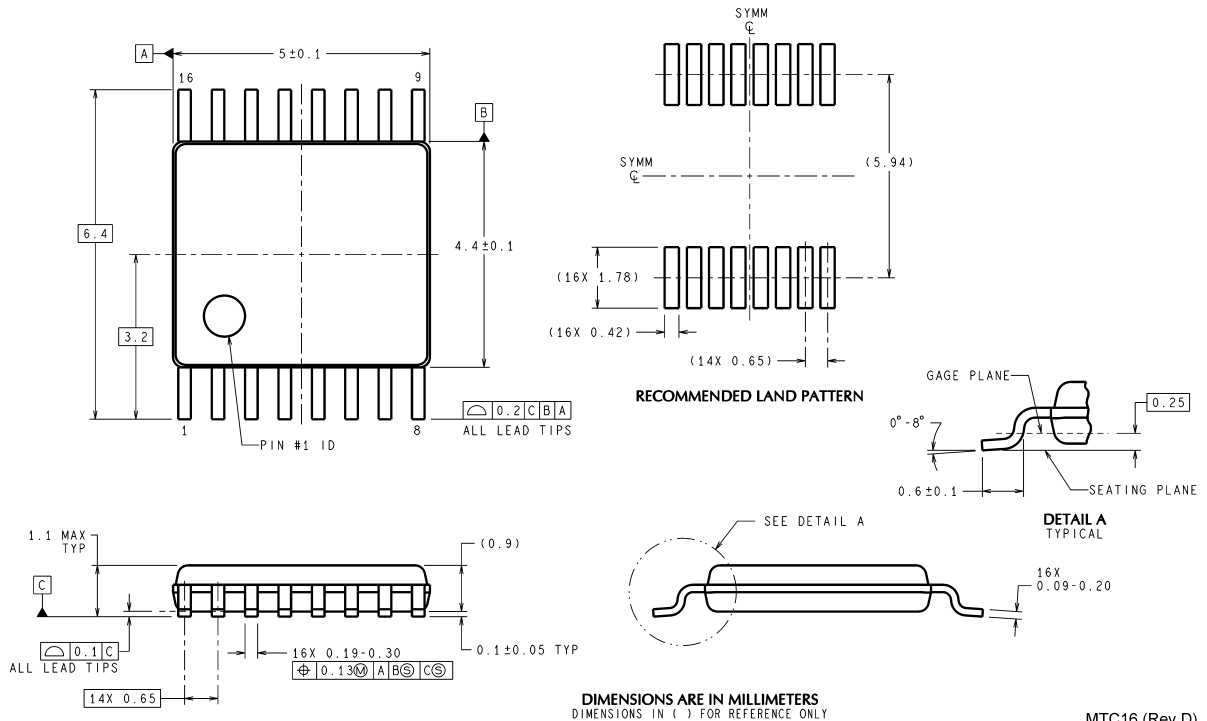

**TSSOP Package (MT)**  
**Order Number DS2003TMT**  
**NS Package Number MTC16**

MTC16 (Rev D)

National does not assume any responsibility for use of any circuitry described, no circuit patent licenses are implied and National reserves the right at any time without notice to change said circuitry and specifications.

For the most current product information visit us at [www.national.com](http://www.national.com).

**LIFE SUPPORT POLICY**

NATIONAL'S PRODUCTS ARE NOT AUTHORIZED FOR USE AS CRITICAL COMPONENTS IN LIFE SUPPORT DEVICES OR SYSTEMS WITHOUT THE EXPRESS WRITTEN APPROVAL OF THE PRESIDENT AND GENERAL COUNSEL OF NATIONAL SEMICONDUCTOR CORPORATION. As used herein:

1. Life support devices or systems are devices or systems which, (a) are intended for surgical implant into the body, or (b) support or sustain life, and whose failure to perform when properly used in accordance with instructions for use provided in the labeling, can be reasonably expected to result in a significant injury to the user.
2. A critical component is any component of a life support device or system whose failure to perform can be reasonably expected to cause the failure of the life support device or system, or to affect its safety or effectiveness.

**BANNED SUBSTANCE COMPLIANCE**

National Semiconductor certifies that the products and packing materials meet the provisions of the Customer Products Stewardship Specification (CSP-9-111C2) and the Banned Substances and Materials of Interest Specification (CSP-9-111S2) and contain no "Banned Substances" as defined in CSP-9-111S2.

**National Semiconductor**  
**Americas Customer Support Center**  
 Email: [new.feedback@nsc.com](mailto:new.feedback@nsc.com)  
 Tel: 1-800-272-9959

**National Semiconductor**  
**Europe Customer Support Center**  
 Fax: +49 (0) 180-530 85 86  
 Email: [europe.support@nsc.com](mailto:europe.support@nsc.com)  
 Deutsch Tel: +49 (0) 69 9508 6208  
 English Tel: +44 (0) 870 24 0 2171  
 Français Tel: +33 (0) 1 41 91 8790

**National Semiconductor**  
**Asia Pacific Customer Support Center**  
 Email: [ap.support@nsc.com](mailto:ap.support@nsc.com)

**National Semiconductor**  
**Japan Customer Support Center**  
 Fax: 81-3-5639-7507  
 Email: [jpn.feedback@nsc.com](mailto:jpn.feedback@nsc.com)  
 Tel: 81-3-5639-7560

This datasheet has been download from:

[www.datasheetcatalog.com](http://www.datasheetcatalog.com)

Datasheets for electronics components.